

- Bracket molded from reinforced polypropylene
- Holds one cylinder from 4.0 to 12.0 inch diameter
- All material, injection molding, finishing, packaging, and labor made 100% in the USA and Canada

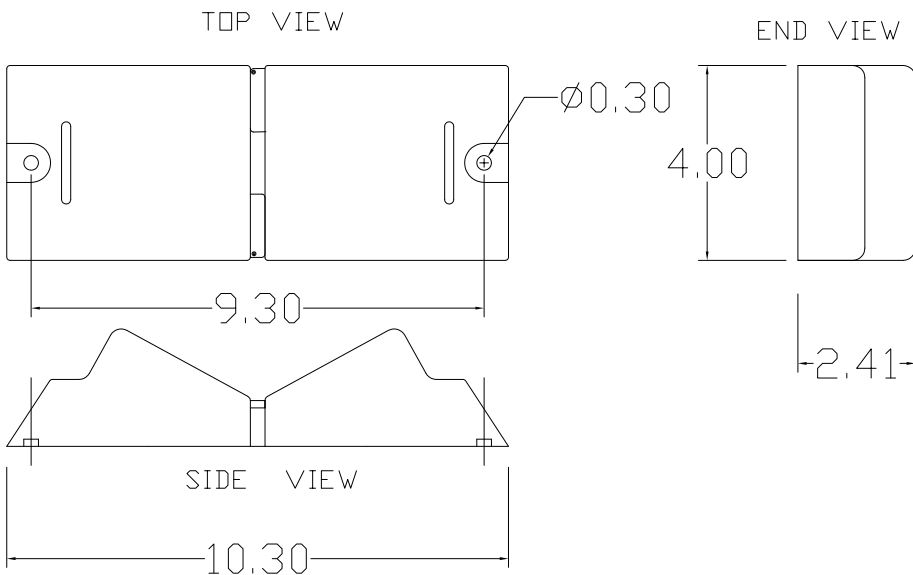

First Safety model G-110 is equipped with Cylinder Chain Sets. These welded steel chains allow **compliance with NFPA1, CalOSHA, and UFC requirements** for secondary cylinder support, and add an improved level of safety for any installation.



- Includes both strap and security chain sets
- Support straps are 1.5 inch wide by 54 inch long polypropylene with steel cinch buckle and rate a robust 1138 PSI. Straps and chain enable the cylinders to be held tight and secure against the brackets
- Unit is first set to designated cylinder diameter (8-10 inch), with recessed set screws locking in width position
- Permanently mounts to wall using your fasteners (1/4" diameter recommended)
- Dimensions: 4"L. x 10.375"W. x 2.375"H.
- Weight: 2.2 lbs
- Ships via UPS or truck for greater quantity orders
- Shipping Dimensions: 10" x 6" x 4"
- Shipping Weight (with packaging): 3 lbs