

- All steel construction bench mounted brackets
- Holds one cylinder from 4.0 to 12.0 inch diameter
- All steel, finishing, packaging, and labor made 100% in the USA and Canada

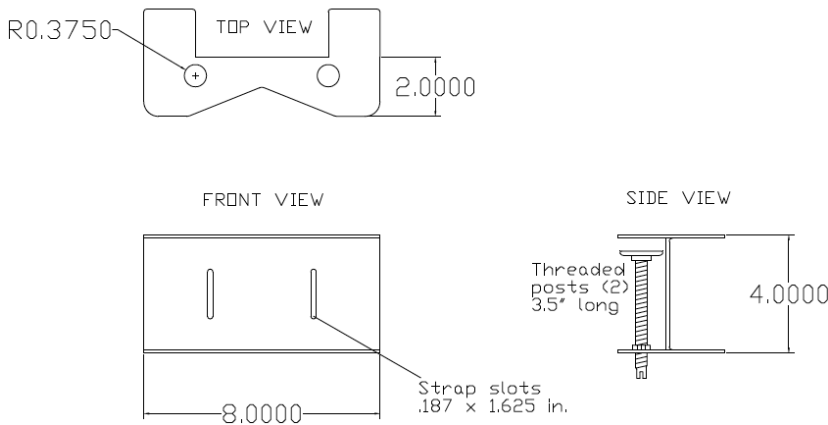

First Safety gas cylinder brackets and racks are equipped with chain slots to easily refit with Model G-105 Cylinder Chain Sets. Adding these welded steel chains allow **compliance with NFPA1, CalOSHA, and UFC requirements** for secondary cylinder support, and add an improved level of safety for any installation.



- Mounts to bench or table tops using dual 3/8 inch diameter swivel pad faced clamping posts with screwdriver slots for attaching to tables and benches. Clamps to tables 1 to 2.75 inches thick
- Vinyl grip pads help assure firm attachment
- Constructed from 11 Gauge hot rolled steel
- Edges are protected with steel reinforced vinyl edge guarding to help maintain your cylinders and provide extra grip
- Steel parts are sealed with powder paint to assure long service life and chemical resistance
- Support straps are 1.5 inch wide by 54 inch long polypropylene with steel cinch buckle and rate a robust 1138 PSI and are the primary means of support as they enable the cylinders to be held tight and secure against the brackets
- Chain sets (G-105) are optional and can be easily retrofit as a second means of support
- Dimensions: 4.25"L. x 8"W. x 4"H.
- Weight: 3 lbs
- Ships via UPS or truck for greater quantity orders
- Shipping Dimensions: 10" x 6" x 4"
- Shipping Weight (with packaging): 3 lbs