

- All stainless steel construction wall mounted brackets
- Holds two cylinders from 4.0 to 12.0 inch diameter
- All steel, finishing, packaging, and labor made 100% in the USA and Canada

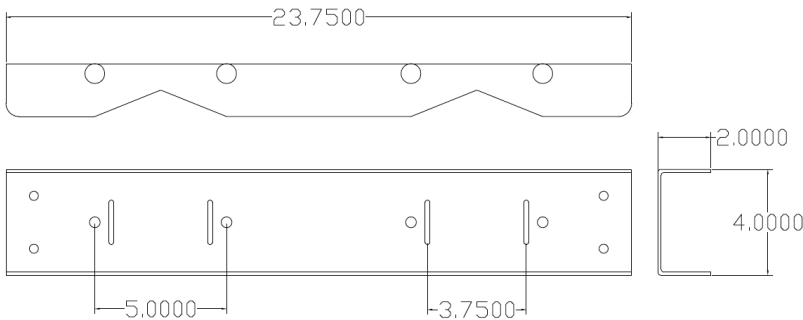

First Safety gas cylinder brackets and racks are equipped with chain slots to easily refit with Model G-105 Cylinder Chain Sets. Adding these welded steel chains allow **compliance with NFPA1, CalOSHA, and UFC requirements** for secondary cylinder support, and add an improved level of safety for any installation.

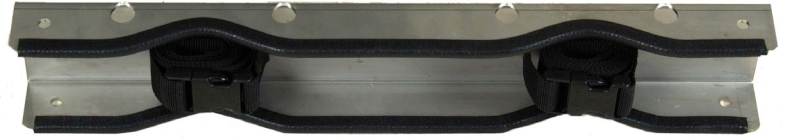

- Constructed from 12 Gauge Type 304 stainless steel
- Edges are protected with steel reinforced vinyl edge guarding to help maintain your cylinders and provide extra grip
- Support straps are 1.5 inch wide by 54 inch long polypropylene with nylon snap buckle and rate a robust 1138 PSI and are the primary means of support as they enable the cylinders to be held tight and secure against the brackets
- Chain sets (G-105) are optional and can be easily retrofit as a second means of support (2 required)
- Dimensions: 24" L. x 4" W. x 2" H.
- Weight: 7 lbs
- Ships via UPS or truck for greater quantity orders
- Shipping Dimensions: 25" x 5" x 3"
- Shipping Weight (with packaging): 7 lbs